



VL SHEAVES/CABLE UPGRADE KIT INSTRUCTIONS

TABLE OF CONTENTS

CHAPTER	TITLE	PAGE
1	SAFETY	1
1.1	Introduction	1
1.2	Safety Definitions	1
1.3	Equipment Safety Labels	1
1.4	Safety Rules	1
2	ASSEMBLY AND INSTALLATION	3
2.1	Reeving the Tubes	3
2.2	Assembling the Platform	3
2.3	Mounting Platform Onto Frame	3
2.4	Adjusting Cable Tension	3
3	REEVING THE WINCH.....	7
3.1	Reeving the R15 Winch.....	7
3.2	Reeving the R18 Winch.....	7
4	OPERATION.....	11
4.1	Pre-Operative Checks	11
4.2	Testing Winch Operation	12
4.3	Raising and Lowering the Platform.....	12
4.4	Securing Lift When Not In Use.....	13
5	INSPECTION AND MAINTENANCE	15
5.1	General Maintenance Rules.....	15
5.2	Wire Rope Inspection Procedure.....	15
6	TROUBLESHOOTING.....	17
7	PARTS LISTS.....	19
7.1	A-B Load Tube.....	19
7.2	C-D Load Tube.....	20
7.3	A-D and B-C Spreader Tubes.....	21
	ONE YEAR LIMITED WARRANTY	23

LIST OF FIGURES

FIGURE	DESCRIPTION	PAGE
2-1	Cable Tension Adjustment	5
3-1	Reeving the R15 Winch.....	8
3-2	Reeving the R18 Winch.....	9
5-1	Wire Rope Components	16
7-1	A-B Load Tube Assembly	19
7-2	C-D Load Tube Assembly	20
7-3	A-D and B-C Spreader Tube Assembly	21

1 SAFETY

1.1 INTRODUCTION

Your Reimann & Georger Corporation Marine Products VL Sheaves/Cable Upgrade Kit will provide lifting performance, long term economics and safety advantages to your vertical lift that no other type of lift can match. However, even a well-designed and well-built lift can malfunction or become hazardous in the hands of an inexperienced and/or untrained user. Therefore, read this manual, your vertical lift manual, and related equipment manuals thoroughly before installing this kit and operating your lift to provide maximum safety for all operating personnel, and to get the maximum benefit from your equipment.

1.2 SAFETY DEFINITIONS

A safety message alerts you to potential hazards that could hurt you or others or cause property damage. The safety messages or signal words for product safety signs are **DANGER**, **WARNING**, and **CAUTION**. Each safety message is preceded by a safety alert symbol and is defined as follows:

DANGER: Indicates an imminently hazardous situation which, if not avoided, **will** cause death or serious injury. This safety message is limited to the most extreme situations.

WARNING: Indicates a potentially hazardous situation which, if not avoided, **could** result in death or serious injury.

CAUTION: Indicates a potentially hazardous situation which, if not avoided, **may** result in minor or moderate injury. It may also be used to alert against unsafe practices and property-damage-only accidents.

1.3 EQUIPMENT SAFETY LABELS

These labels warn you of potential hazards that could cause injury. Read them carefully. If a label comes off or becomes illegible, contact a Reimann & Georger Corporation dealer for a replacement.

1.4 SAFETY RULES



WARNING:

DO NOT INSTALL THIS KIT AND OPERATE THE LIFT WITHOUT READING BOTH THIS MANUAL AND YOUR VERTICAL LIFT MANUAL. FAILURE TO DO THIS CAN LEAD TO EQUIPMENT MISUSE WITH RESULTING DAMAGE AND/OR SERIOUS PERSONAL INJURY. CONTACT YOUR RGC® MARINE DEALER IF YOU HAVE ANY QUESTIONS.

1. Never use this kit beyond its rated capacity. This can damage the kit assembly, lift, and/or boat with resulting serious personal injury.
2. Do not install this kit if any part shows any sign of damage.
3. Immediately replace any components found to be defective.
4. Never try using any part of this kit in an application for which it was not designed.
5. Do not weld or otherwise modify any part of this kit. Such alterations may weaken the structural integrity of the lift and void the warranty.
6. The following precautions must be observed when lifting any part of this equipment:
 - a. Be sure of your footing.
 - b. Bend your knees and lift with your legs.

- c. Hold the equipment section close to your body when lifting.
- 7. Wear heavy leather gloves when handling wire rope. Insufficient hand protection when handling wire rope can cause personal injury.
- 8. Insure the pulleys spin freely. If any pulley binds, replace it before assembling the platform.
- 9. Insure that all bolts and nuts are fastened securely prior to mounting the platform to the frame.
- 10. Insure that the assembled platform is square at all four corners before installing onto the frame.
- 11. The handwheel or power drive must turn clockwise when raising the platform. The brake pawl must click, indicating that the brake is operative.



WARNING:

IF YOU HAVE TO TURN THE HANDWHEEL COUNTERCLOCKWISE TO RAISE THE PLATFORM, YOU HAVE REEVED THE WINCH INCORRECTLY. YOU WILL IMMEDIATELY ENCOUNTER STRONG RESISTANCE WHICH CAN LEAD TO WINCH DAMAGE AND/OR CABLE BREAKAGE.

- 12. The handwheel or power drive must turn counter-clockwise when lowering the platform. Counter-clockwise rotation of the handwheel allows the self-activating brake mechanism to provide a controlled lowering of the platform.



WARNING:

IF YOU HAVE TO LOWER THE PLATFORM BY TURNING THE HANDWHEEL CLOCKWISE, YOU HAVE REEVED THE WINCH INCORRECTLY. THE BRAKE PAWL WILL NOT BE EFFECTIVE WHICH CAN CAUSE AN UNCONTROLLED SPIN-DOWN OR “FREEWHEEL” OF THE HANDWHEEL. IF FREEWHEELING OCCURS, NEVER TRY TO STOP IT.

- 13. Do not try making any adjustments on any part of the lift during operation.

2 ASSEMBLY AND INSTALLATION

Assembling this kit and installing it onto your vertical lift consists of the following steps which should be performed in conjunction with your vertical lift instructions.

1. Reeving the Tubes
2. Assembling the Platform
3. Mounting Platform Onto Frame
4. Adjusting Cable Tension

After completing these steps, you can reeve your winch as detailed in Chapter 3.

2.1 REEVING THE TUBES

The major components of this kit are an A-B and C-D load tube, an A-D and B-C spreader tube, and the associated cable assemblies, mounting hardware, and sheaves. Figures 7-1 through 7-3 in Chapter 7 show exploded detail on how to reeve each of these tubes using the respective hardware supplied with each tube. When reeving each tube, observe the following precautions:

1. Do not use any part that shows any sign of damage.
2. Wear heavy leather gloves when handling wire rope. Insufficient hand protection when doing this can cause personal injury.
3. Do not use any sheave that does not spin freely.

2.2 ASSEMBLING THE PLATFORM

After all four tubes are reeved, assemble them to create a platform as described in Chapter 3 of your vertical lift manual. After completing this procedure, insure that all bolts and nuts are fastened securely prior to mounting the platform to the frame. The assembled platform must be square at all four corners.

2.3 MOUNTING PLATFORM ONTO FRAME

Before mounting the platform, insure that the frame sides of the lift have been assembled and positioned as described in Chapter 3 of your vertical lift manual. Then complete the platform mounting and mount the lower diagonal braces as described in your vertical lift manual. When lifting the platform, follow the safety procedures described in Chapter 1 of this manual.

2.4 ADJUSTING CABLE TENSION

1. Position the platform near the bottom end of its lifting range. Insure the platform is level.
2. Refer to Figure 2-1. Fasten the cable end loops to the bracket provided at the bottom of each of the four vertical legs using the 1/2" x 3-1/2" bolts and 1/2" locknuts supplied with your vertical lift assembly.



CAUTION:

DO NOT "JAM TIGHT" THESE LOWER CABLE ANCHORS OR YOU WILL BREAK OFF THE BRACKET PLATES.

3. Using a 7/8" open-end wrench, tighten the cable studs opposite the cable end loops in the following order. The following step numbers correspond to the step numbers shown in Figure 2-1.

Step 1: Tighten down the nut to add tension to the B-C spreader tube cable.

Step 2: Tighten down the nut to add tension to the A-D spreader tube cable. Check that the B-C and A-D spreader tube cables are equal in tension and that the platform is level.

Step 3: Tighten down the nut to add tension to the first C-D load tube cable.

Step 4: Tighten down the nut to add tension to the second C-D load tube cable. Check that both C-D load tube cables are equal in tension and that the platform is level.

4. Add and tighten the jam nuts to the cable nuts to lock the position.
5. During operation, when the platform is being lifted, it is normal for the two cables in the C-D load tube to alternate from being tense to going slack. If you notice this, it is not necessary to further tighten down the nuts.
6. If the boat is not lifting level because the stern is lifting higher or lower than the bow, the spreader tube cables are not tight enough. Repeat the first two substeps under Step 3 above.

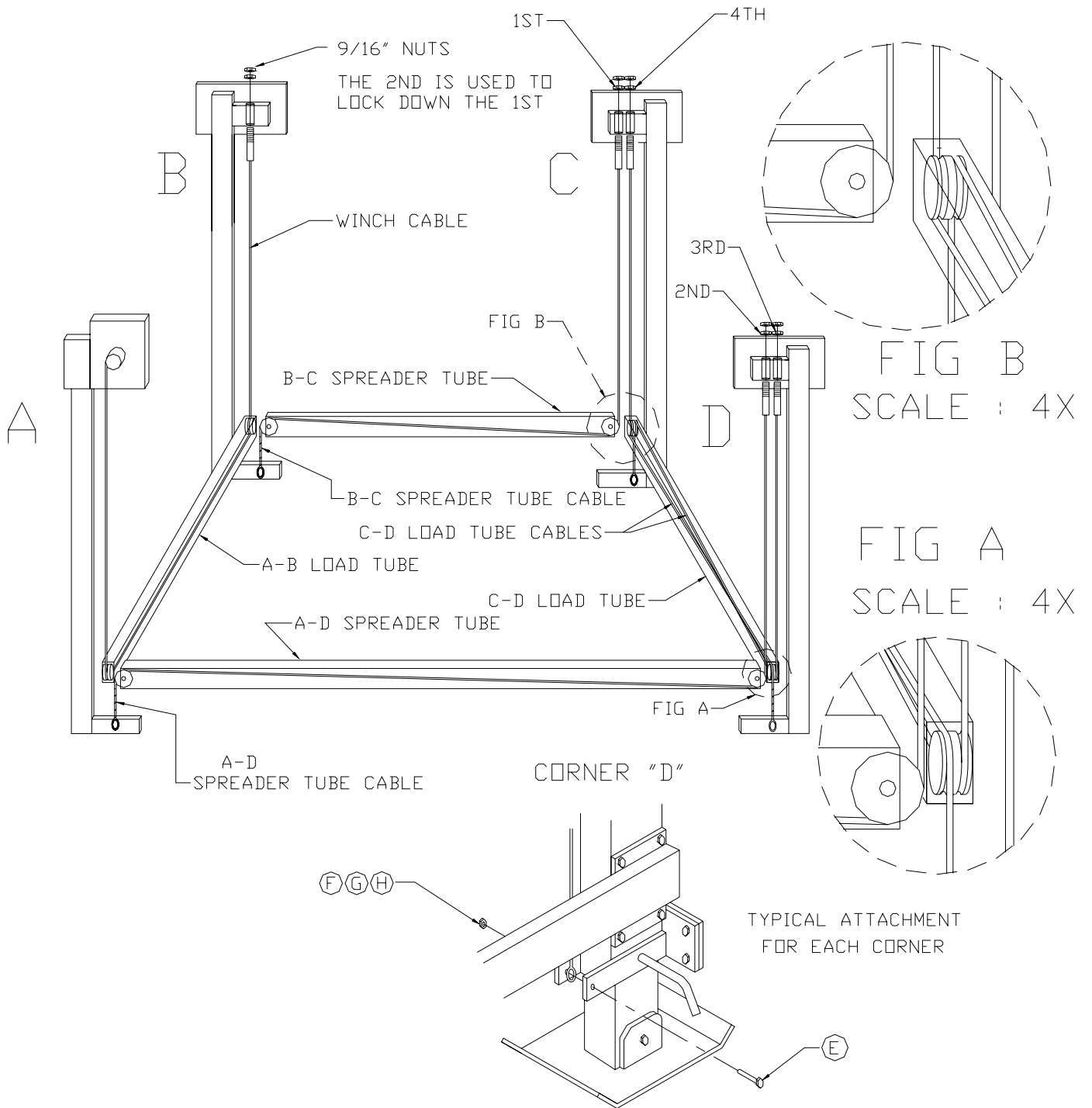

Figure 2-1.
Cable Tension Adjustment

3 REEVING THE WINCH

After adjusting the platform cable tension as described in Section 2.4, mount the winch as described in your vertical lift instruction manual and then reeve the winch. If you have an R15 winch, use the reeving procedure described in Section 3.1. If you have an R18 winch, use the reeving procedure described in Section 3.2.

3.1 REEVING THE R15 WINCH

1. Refer to Figure 3-1. Remove the cover from the winch housing by loosening only the three 3/8" bolts.
2. Position the winch drum so that the set screw faces at a 90° angle or is perpendicular to, the vertical leg "A".
3. Starting from the bottom of winch, reeve the cut end of cable between the cable guide roller assembly, and up the back side of winch. Wrap the cable over the top of winch drum and insert cable into the hole on the drum as shown in Figure 3-1. **Keep the cable flush with the drum wall.**



CAUTION:

DO NOT ALLOW END OF CABLE TO EXTEND OUT OF THE WINCH DRUM.

4. Secure the cable by tightening down the set screw using the Allen wrench included in the VL winch hardware bag.



WARNING:

WHEN REEVING THE WINCH, CLOCKWISE ROTATION OF THE HANDWHEEL MUST RAISE, NOT LOWER, THE PLATFORM. IF CLOCKWISE ROTATION OF THE HANDWHEEL LOWERS THE PLATFORM, YOU HAVE REEVED THE WINCH INCORRECTLY. AN UNCONTROLLED FREEWHEELING CAN BE TRIGGERED WITH THE WEIGHT OF A BOAT.

FREEWHEELING CAN CAUSE EQUIPMENT OR BOAT DAMAGE. HOWEVER, IF FREEWHEELING OCCURS, NEVER TRY TO STOP IT. THIS CAN CAUSE SERIOUS PERSONAL INJURY.

5. When wrapping the drum, do not allow any horizontal gaps in the cable winding.
6. When the winch reeving is done, the guard must be reinstalled. Do NOT operate the winch without the guard installed.
7. Refer to Figure 2-1. Tighten down the nut to fasten the A-B load tube cable stud to leg B. Add and tighten a jam nut to the cable nut to lock the position.

3.2 REEVING THE R18 WINCH

1. Refer to Figure 3-2. Remove the top and bottom guards from the winch housing by removing the (4) 1/4 -20 pan head screws.
2. Position the winch drum so that the set screw faces at a 90° angle or is perpendicular to, the vertical leg "A".
3. Starting from the bottom of winch, reeve the cut end of cable between the cable guide roller assembly, and up the back side of winch. Wrap the cable over the top of winch drum, inserting cable into the hole on the LEFT SIDE of drum as shown in Figure 3-2. **Keep the cable flush with the drum wall.**



CAUTION:
DO NOT ALLOW END OF CABLE TO EXTEND OUT OF THE WINCH DRUM.

4. Secure the cable by tightening down the set screw using the Allen wrench included in the VL winch hardware bag.



WARNING:
WHEN REEVING THE WINCH, CLOCKWISE ROTATION OF THE HANDWHEEL MUST RAISE, NOT LOWER, THE PLATFORM. IF CLOCKWISE ROTATION OF THE HANDWHEEL LOWERS THE PLATFORM, YOU HAVE REEVED THE WINCH INCORRECTLY. AN UNCONTROLLED FREEWHEELING CAN BE TRIGGERED WITH THE WEIGHT OF A BOAT.

FREEWHEELING CAN CAUSE EQUIPMENT OR BOAT DAMAGE. HOWEVER, IF FREEWHEELING OCCURS, NEVER TRY TO STOP IT. THIS CAN CAUSE SERIOUS PERSONAL INJURY.

5. When wrapping the drum, do not allow any horizontal gaps in the cable winding.
6. When the winch reeving is done, the guards must be reinstalled. Do NOT operate the winch without the guards installed.
7. Refer to Figure 2-1. Tighten down the nut to fasten the A-B load tube cable stud to leg B. Add and tighten a jam nut to the cable nut to lock the position.

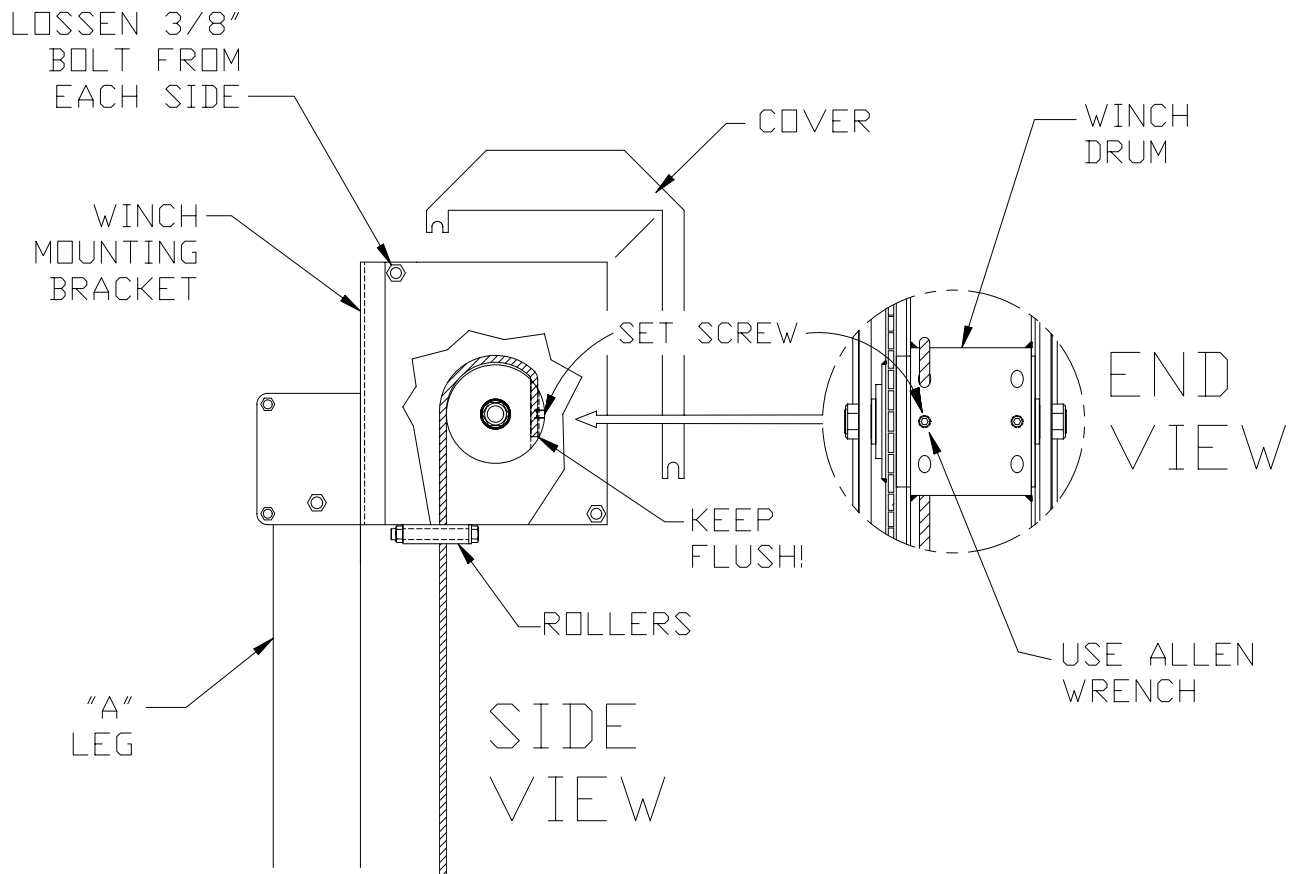

Figure 3-1
Reeving the R15 Winch

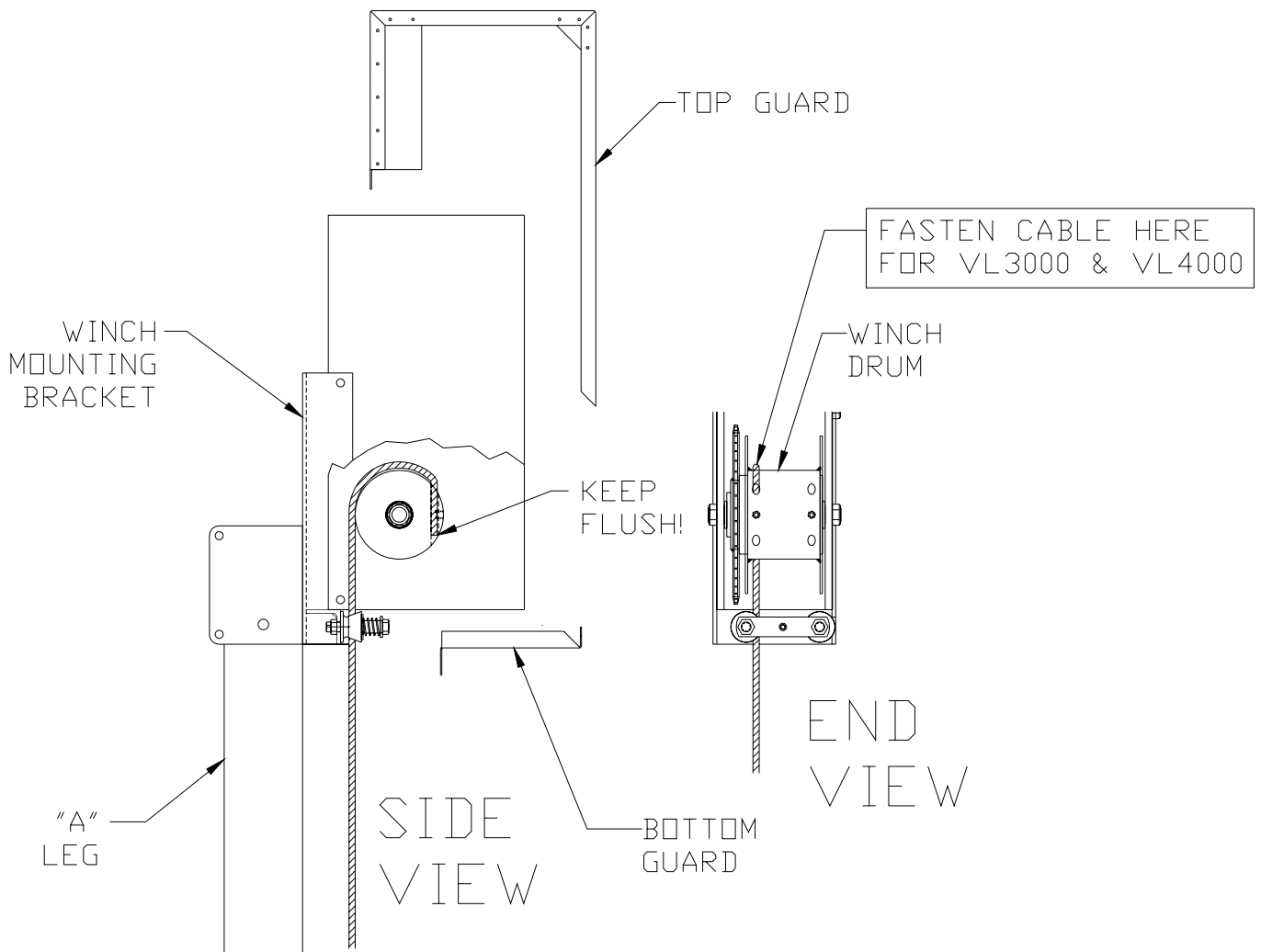

Figure 3-2.
Reeving the R18 Winch

4 OPERATION

4.1 PRE-OPERATIVE CHECKS

1. Review the following Pre-Lifting Checklist. Only those who have read and understood this manual, the vertical lift manual, and related equipment manuals are qualified to do this inspection.

- Insure the lift installation will clear all power lines and obstructions.
- Insure all structural members of the lift are free of defects and damage that may affect the integrity.
- Insure that an electric drive, if used, has been inspected and installed by a certified electrician in accordance with local electrical codes. A Ground Fault Circuit Interrupter (G.F.C.I.) must be installed by your electrician and work properly.
- Insure that any user or dealer installed locking devices have been removed before operating the lift.
- Operate the lift first without, and then with, your boat on the platform to test the operation of both the lift and the winch.
- Insure the boat is properly positioned on the lift before doing any raising or lowering.
- Insure the lift is not being used beyond its rated capacity.
- Insure any drain plug is in place on the boat before launching.
- Conduct the wire rope inspection procedure described in Chapter 5 at least monthly.
- Insure the leg pins connect the vertical legs to the adjustable legs. Insure the leg height has been properly adjusted according to the water depth.
- Insure the frame and platform fastenings are tight.
- Insure the lower diagonal braces are installed in each corner.
- Insure the frame is level and square according to the dimensions shown in the installation chapter of the vertical lift manual.
- Insure the cable end loops of the load and spreader tubes are fastened to the bracket at the bottom of each vertical leg.
- Insure the cable studs opposite the cable end loops in the platform assembly are tight. If tightening is needed, follow the sequence described in Section 2.4 of Chapter 2. Then tighten the jam nuts to the cable nuts to lock the position.
- Insure the winch is securely fastened to vertical leg "A".
- Insure the handwheel has been attached to the winch hubplate.
- Insure the spinner knob is attached to the handwheel using the preassembled hardware.
- Insure the A-B load tube cable stud is fastened to leg B to enable winch operation.
- Insure set screw securing wire rope end to the drum is tight and in good condition.
- When facing the front of the handwheel, insure that the wire rope winds and unwinds from the left side of the winch. This reeving will raise the platform when the handwheel is turned clockwise, and lower the platform when the handwheel is turned counterclockwise. The brake pawl must click, meaning the brake is operative.

- Insure the guards are in place before operating the winch.
 - Insure the plastic caps are installed onto the tops of the vertical legs and the ends of the upper short horizontal tubes.
2. Read the lift manual and insure that everyone understands the proper operating procedure.
 3. When using a power drive, understand the use of all controls and connections provided with it.
 4. Do not use the lift if it shows any signs of damage.
 5. Insure that all bolts and nuts are fastened securely prior to operation.
 6. Check that the winch is reeved properly as described in Chapter 3.
 7. Never try lifting anything other than a boat with this lift.
 8. Do not operate the lift under the influence of drugs, alcohol, or medication.
 9. Never try to lift or launch your boat in rough water conditions. This can damage your boat and/or the lift.

4.2 TESTING WINCH OPERATION

After the lift installation is complete, it is important that the winch functions properly. Test the winch operation as follows:

1. Raise the empty platform about one fourth the way up and release the handwheel. If the winch is functioning properly, the brake mechanism will hold the platform at any position. The handwheel or power drive must turn clockwise when raising the platform. The brake pawl must click, indicating that the brake is operative.



CAUTION:

IF YOU HAVE TO TURN THE HANDWHEEL COUNTERCLOCKWISE TO RAISE THE PLATFORM, YOU HAVE REEVED THE WINCH INCORRECTLY. YOU WILL IMMEDIATELY ENCOUNTER STRONG RESISTANCE WHICH CAN LEAD TO WINCH DAMAGE AND/OR CABLE BREAKAGE.

2. Repeat Step 1 in the half, three-quarters, and full lift positions.



WARNING:

IF THE HANDWHEEL STARTS TO FREELY SPIN DOWN FROM ANY OF THESE TEST POSITIONS, NEVER TRY TO STOP IT. DO NOT USE A LIFT IN THIS CONDITION.

3. Lower the empty platform to repeat steps 1 and 2 with your boat on the lift. The handwheel or power drive must turn counter-clockwise when lowering the platform. This counter-clockwise rotation allows the self-activating brake mechanism to stop the platform lowering as soon as the operator stops turning the handwheel. Make sure this brake mechanism is operative.
4. Contact your authorized dealer if the winch mechanism fails to perform as described in this section. Do NOT tamper with the winch mechanism.

4.3 RAISING AND LOWERING THE PLATFORM

1. Raise the platform by turning the handwheel clockwise. The self-activating brake mechanism will hold the platform at any desired height.

2. Platform should be raised a minimum of 1 foot between bottom of boat and highest potential water table height for your geographic area.
3. Lower the platform by turning the handwheel counterclockwise. Do not continue lowering the platform after the boat floats freely from the platform. Excessive winch cable slack may cause cable, lift, and winch damage.
4. Keep fingers and clothing clear of all moving parts. Keep people clear during operation of the lift.
5. Never allow people in the boat any time it is suspended above the water on the lift.



WARNING:

DO NOT STAND OR WALK ON THE LIFT PLATFORM WHILE IT IS IN ANY RAISED POSITION. THIS CAN CAUSE SERIOUS PERSONAL INJURY.

6. Check the lift periodically for frayed cables and/or binding pulleys.
7. When using a power drive, avoid sudden stops.

4.4 SECURING LIFT WHEN NOT IN USE

At the end of operation, secure the lift to prevent unauthorized use. Proceed as follows:

1. Raise the platform to the desired height.
2. Padlock the handwheel to the post or lock out your power drive to prevent unauthorized use when your boat lift is unattended.

5 INSPECTION AND MAINTENANCE

5.1 GENERAL MAINTENANCE RULES

1. Read and follow all the general maintenance rules given in Chapter 5 of your vertical lift manual before doing any work on the lift.
2. Do not allow persons other than authorized service personnel to repair any part of this lift.
3. Both the lift and winch to which this kit is installed require annual inspection, maintenance and storage procedures as described in Chapter 5 of your vertical lift manual.
4. After every winch maintenance, test the winch mechanism as described in Chapter 4 before letting anyone use the lift.
5. At least once a year, check the sheaves to insure that they spin freely. If they bind, replace them immediately.
6. When doing maintenance on this kit, give particular attention to cable inspection as described in Section 5.2.

5.2 WIRE ROPE INSPECTION PROCEDURE

Inspect the wire rope at least once per month for signs of wear, damage, or pinching. Inspect the entire wire rope working length. Thoroughly inspect the rope sections that pass over sheaves or drums, or that make opposing turns. Inspect wire rope and end attachments carefully. While inspecting, examine sheaves, guards, guides, drums, flanges, and other surfaces contacting wire rope during operation. Correct any condition harming the rope in use or other damage or worn surfaces at this time.



CAUTION:

WEAR HEAVY LEATHER GLOVES WHEN HANDLING WIRE ROPE. INSUFFICIENT HAND PROTECTION WHEN HANDLING WIRE ROPE CAN CAUSE PERSONAL INJURY.

Remove and immediately replace wire rope with one or more of the following defects:

1. Corrosion
2. Broken wires:
 - (a) One or more valley breaks. A valley break is a wire break occurring in the valley between two adjacent strands.
 - (b) Six randomly distributed broken wires in one rope lay. A rope lay is the length of rope along which one strand makes a complete revolution around the rope. See Figure 5-1. If a broken wire or wires are localized in the end attachment of an operating rope and making a new attachment can eliminate this condition, this may be done instead of replacing the entire rope. Keeping the rope clean and wound evenly on the winch drum will increase its life and efficiency.
3. Abrasion: Scrubbing, flattening or peening causing loss of more than one-third of the original diameter of the outside wires.
4. Kinking: Severe kinking, crushing, bird caging or other damage causing distortion of the rope structure. Bird caging is a bulging in the cable caused by the individual wires becoming untwisted. This untwisting of individual wires is usually caused by impact loading on the cable (such as a sudden stop).

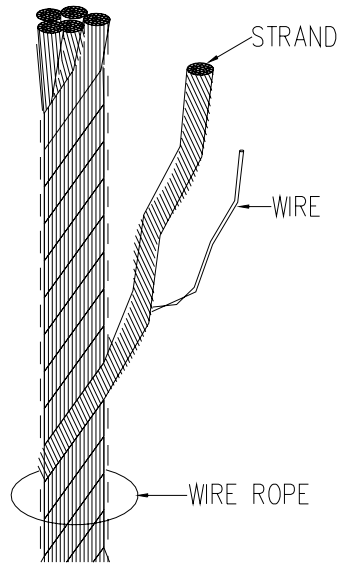

Figure 5-1.
Wire Rope Components

5. Heat damage: Evidence of any heat damage caused by a torch or by contact with electrical wires.
6. Reduction of more than $\frac{3}{64}$ inch from $\frac{1}{4}$ inch diameter cable, $\frac{15}{256}$ inch (about $\frac{1}{16}$ inch) from $\frac{5}{16}$ inch diameter cable, or $\frac{9}{128}$ inch (about $\frac{1}{16}$ inch) from $\frac{3}{8}$ inch diameter cable. Marked reduction in diameter indicates core deterioration.

6 TROUBLESHOOTING

The following chart is intended to assist with troubleshooting problems related to the kit installation. While not all inclusive, the chart outlines the most common causes of a problem and the recommended course of action.

To troubleshoot problems related to the lift installation, refer to the vertical lift instruction manual.

SYMPTOM	CAUSE AND CORRECTIVE ACTION
Winch resists platform raising.	<p>Winch has been reeved incorrectly—winch must turn clockwise to raise platform. See Chapter 3.</p> <p>Steel sheaves binding—inspect/lubricate/replace.</p> <p>Winch cable is rubbing against the winch frame—repeat winch reeving if necessary following Chapter 3.</p>
Winch is operating properly, but platform raising is either difficult or impossible.	<p>Platform is binding because frame is either not square or not set level in the water—refer to Chapter 3 of your vertical lift manual.</p> <p>One or more cables are broken—replace as required.</p> <p>Steel sheaves binding—inspect/lubricate/replace.</p> <p>One or more cables are excessively worn—replace as required and follow monthly wire rope inspection procedure described in Section 5.2.</p> <p>Load exceeds rated capacity—the rated capacity in pounds is the first two digits of your lift number times 100. For example, the VL 30108 has a rated capacity of 30 x 100 or 3000 lbs. Reduce load weight as needed.</p> <p>User or dealer installed locking devices are in place—remove these.</p> <p>Auxiliary equipment such as boating hardware is being improperly hung on lift—remove this equipment permanently.</p>
Boat is not lifting level—stern is lifting higher or lower than the bow.	<p>Frame is not level in the water—relocate pin connections between the adjustable and vertical legs.</p> <p>Frame is level in the water but spreader tube cables are not tight enough—</p> <ol style="list-style-type: none"> 1. Tighten down the cable stud nut to add tension to the B-C spreader tube cable. 2. Tighten down the cable stud nut to add tension to the A-D spreader tube cable. Check that the B-C and A-D spreader tube cables are equal in tension and that the platform is level.

<p>Lowering operation triggers a “freewheeling” of the handwheel.</p>	<p>Winch has been reeved incorrectly—winch must turn counterclockwise to lower the platform. See Chapter 3.</p> <p>Unauthorized brake pawl release has occurred—do not try to correct this yourself. Contact your authorized dealer immediately.</p>
---	--



WARNING:

NEVER RELEASE THE BRAKE PAWL OF THE WINCH. THIS CAN VOID YOUR WARRANTY AND TRIGGER AN UNCONTROLLED SPIN-DOWN OR “FREEWHEEL” OF THE HANDWHEEL. FREEWHEELING CAN CAUSE EQUIPMENT OR BOAT DAMAGE. IF FREEWHEELING OCCURS, NEVER TRY TO STOP IT, AS THIS CAN CAUSE SERIOUS PERSONAL INJURY.

7 PARTS LISTS

Each item number in the following parts lists can be matched with the item number shown on the corresponding assembly drawing as indicated in the following sections.

7.1 A-B LOAD TUBE

Refer to Figure 7-1.

REF #	PART#	QTY	PART DESCRIPTION
1	3600802	1	VL26100, VL26108 & VL26108P WINCH CABLE ASSY: 1/4" X 25'
	3686502	1	VL36108 WINCH CABLE ASSY: 5/16" X 25'
	3603865	1	VL46116 WINCH CABLE ASSY: 5/16 X 25' GALVANIZED
3	5896306	2	HHCS 5/8-11 X 3 1/2"
5	3603846	2	VL SHEAVE BUSHING
7	5896380	2	5/8-11 HEX NUT
	5896414	2	5/8" FLAT WASHER
	5806246	2	5/8" SPLIT LOCK WASHER
9	7308881	2	VL26-36 SHEAVES—SINGLE (3 3/8" O.D. X 1.420" WIDE)
	7307960	2	VL46116 SHEAVES—SINGLE (4 7/16" O.D. X 1.420" WIDE)
10	3603834	1	VL26100 LOAD TUBE
	3603868	1	VL26108P LOAD TUBE
	3603880	1	VL36108 LOAD TUBE
	3603890	1	VL46116 LOAD TUBE

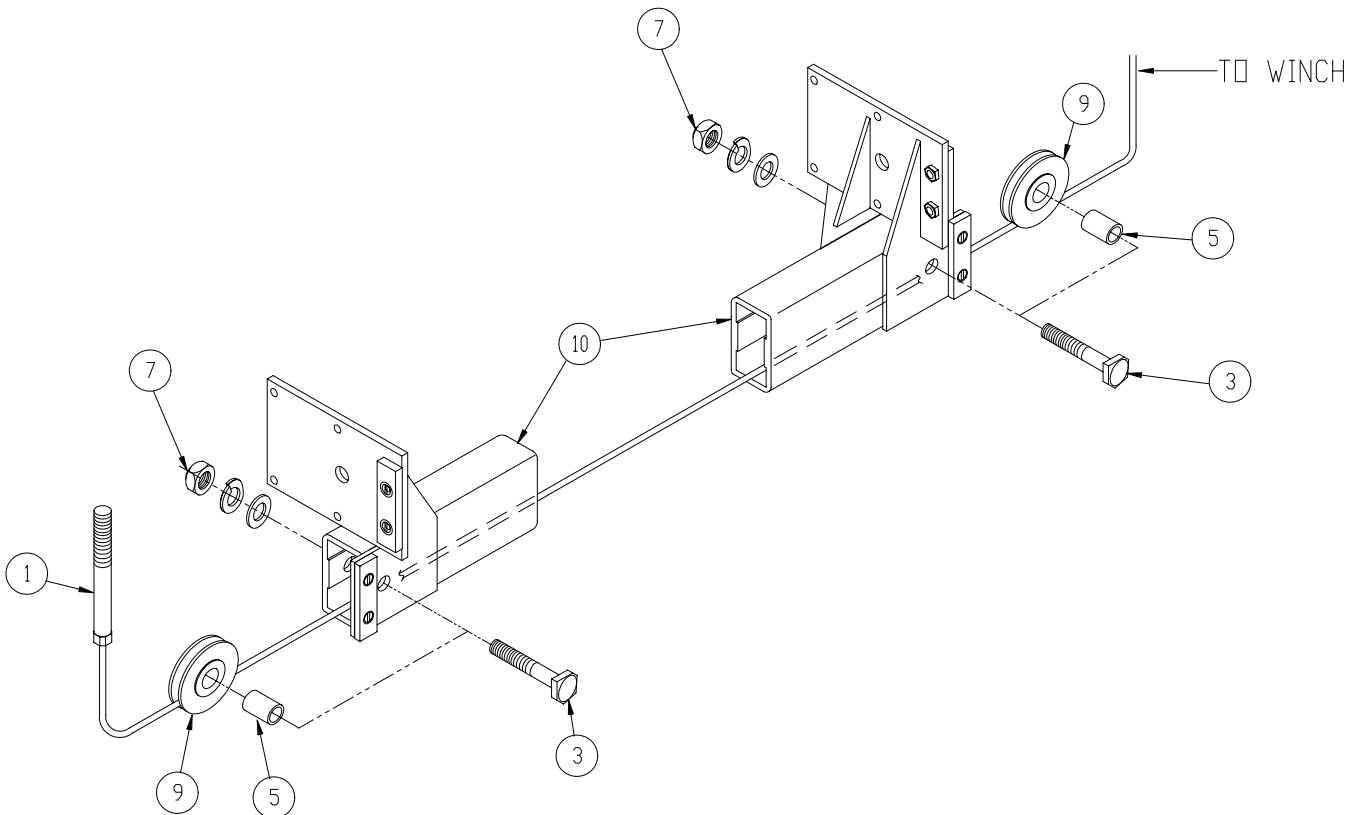

Figure 7-1
A-B Load Tube Assembly

7.2 C-D LOAD TUBE

Refer to Figure 7-2.

REF #	PART#	QTY	PART DESCRIPTION
1		2	C-D LOAD TUBE CABLES
	3686403		VL26100 1/4" X 186 3/4"—BROWN
	3686703		VL26108 & VL26108P 1/4" X 194 3/4"—BLUE
	3686703		VL36108 1/4" X 194 3/4"—BLUE
	3600904		VL46116 5/16" X 204"—GOLD
4	5896380	2	5/8-11 HEX NUT
	5896414	2	5/8" FLAT WASHER
	58062246	2	5/8" SPLIT LOCK WASHER
5	7308882	2	VL26-36 SHEAVES—DOUBLE (3 3/8" O.D. X 1.420" WIDE)
	7307961	2	VL46116 DOUBLE (4 7/16" O.D. X 1.420" WIDE)
6	3603846	2	VL SHEAVE BUSHINGS
8	5896306	2	HHCS 5/8-11 X 3 1/2" BOLTS
11	3603834	1	VL26100 LOAD TUBE
	3603868	1	VL26108P LOAD TUBE
	3603880	1	VL36108 LOAD TUBE
	3603890	1	VL46116 LOAD TUBE

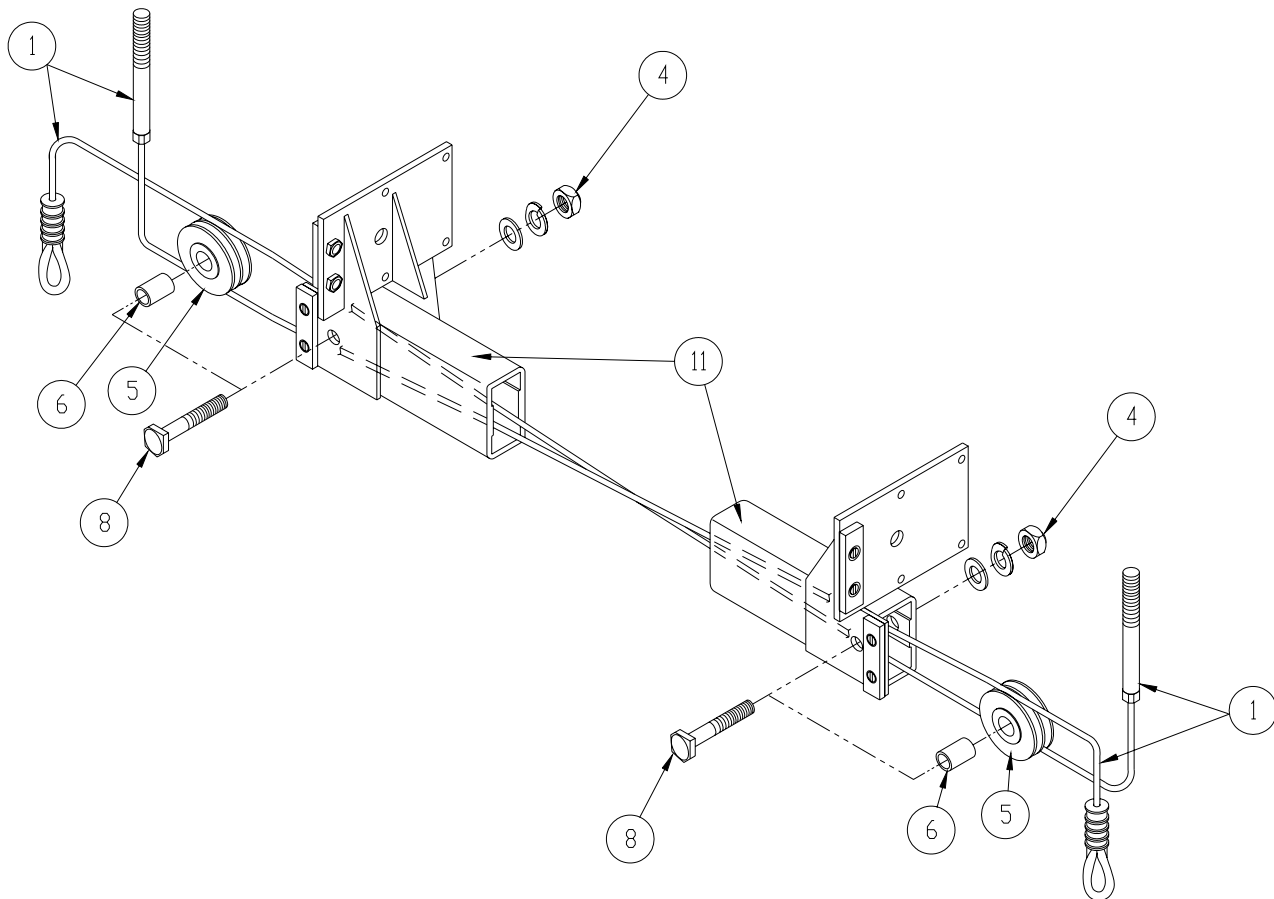

Figure 7-2
CD Load Tube Assembly

7.3 A-D AND B-C SPREADER TUBES

Refer to Figure 7-3.

REF #	PART#	QTY	PART DESCRIPTION
1		1	SPREADER TUBE CABLE
	3686003		VL26100 1/4" X 169 1/2"—RED
	3686003		VL26108 & VL26108P 1/4" X 169 1/2"—RED
	3686303		VL36108 1/4" X 177 1/2" ---YELLOW
	3686603		VL46116 1/4" X 185 1/2"—BLACK
2	5896380	2	5/8-11 HEX NUT
	5896414	2	5/8" FLAT WASHERS
	5806246	2	5/8" SPLIT LOCK WASHERS
5	7308880	2	VL26-46 SHEAVES—SINGLE (3 5/8" O.D. X 1.420" WIDE)
6	3603846	2	VL SHEAVE BUSHINGS
8	5896306	2	HHCS 5/8-11 X 3 1/2" BOLTS
10	3603783	1	VL26100 A-D SPREADER TUBE
	3603783	1	VL26108 & VL26108P A-D SPREADER TUBE
	3603784	1	VL36108 A-D SPREADER TUBE
	3603785	1	VL46116 A-D SPREADER TUBE
	3603783	1	VL26100 B-C SPREADER TUBE
	3603783	1	VL26108 & VL26108P B-C SPREADER TUBE
	3603784	1	VL36108 B-C SPREADER TUBE
	3603785	1	VL46116 B-C SPREADER TUBE

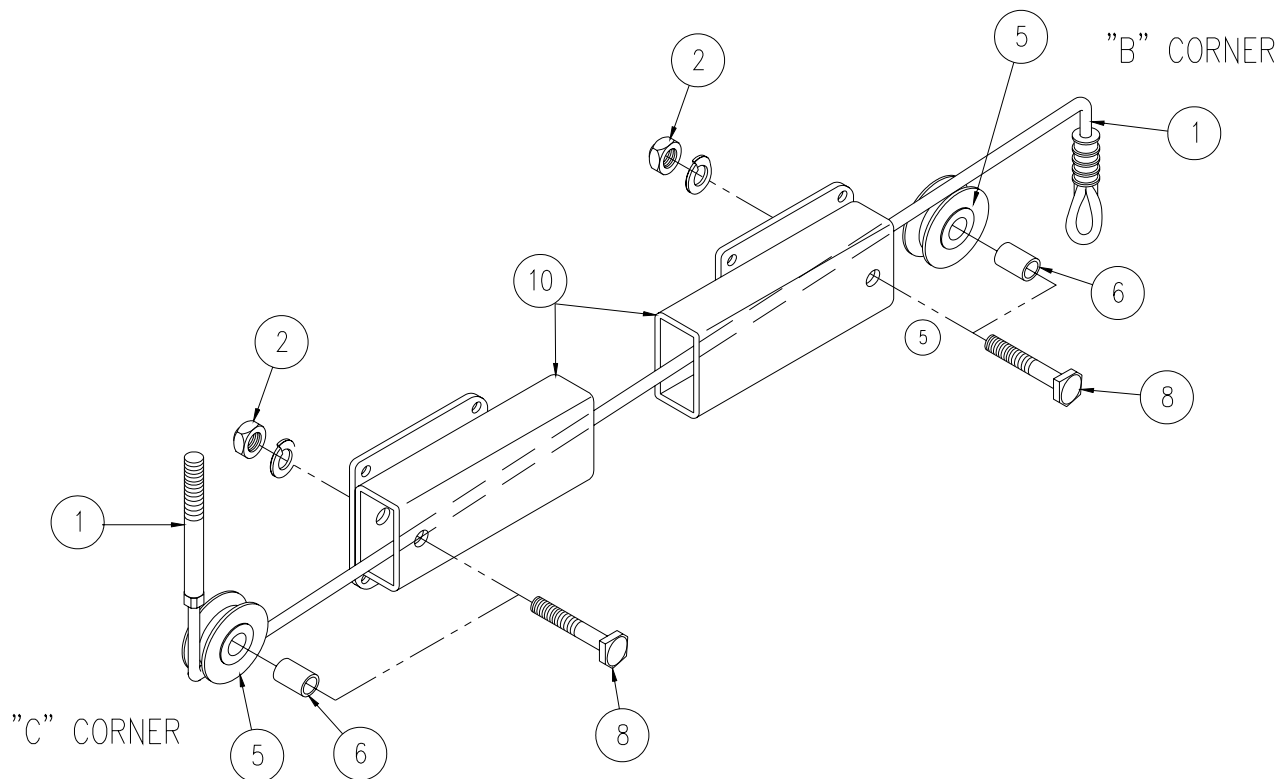

Figure 7-3
A-D and B-C Spreader Tube Assembly
(B-C Spreader Tube Shown Here)

ONE YEAR LIMITED WARRANTY

**Reimann & Georger Corp.
Marine Products
P.O. Box 681
Buffalo, NY 14240**

This product is warranted by RGC® Marine Products to the original purchaser to be free from defects in material and workmanship under normal use for a period of one year from the date of purchase.

During the warranty period, and upon proof of purchase, the product will be repaired or replaced (with the same or similar model) at our option, without charge for either parts or labor when serviced at RGC® Marine Products.

Upon completion of repair, the unit will be returned to the customer freight prepaid. The warranty will not apply to this product if it has been misused, abused, or altered.

NEITHER THIS WARRANTY OR ANY OTHER WARRANTY, EXPRESS OR IMPLIED, INCLUDING IMPLIED WARRANTIES OF MERCHANTABILITY, SHALL EXTEND BEYOND THE WARRANTY PERIOD. NO RESPONSIBILITY IS ASSUMED FOR ANY INCIDENTAL OR CONSEQUENTIAL DAMAGES. SOME STATES DO NOT ALLOW EXCLUSION OR LIMITATION OF INCIDENTAL OR CONSEQUENTIAL DAMAGES, SO THE ABOVE LIMITATIONS OR EXCLUSIONS MAY NOT APPLY TO YOU.

This warranty gives you specific legal rights, and you may also have other rights which vary from state to state.